

Generator Weights and Dimensions

	Without Sound Shield	With Sound Shield
Weight, kg (lb.)		
Wet	2067 (4558)	2466 (5437)
Dry	2006 (4422)	2404 (5301)
Length, mm (in.)	2490 (98.04)	2661 (104.76)
Width, mm (in.)	970 (38.19)	1048 (41.26)
Height, mm (in.)	1086 (42.76)	1174 (46.21)

Above dimension excludes exhaust outlet. Refer to appropriate ADV for detailed dimensions.

Generator Ratings (Prime)

Model Generator (Alternator)	Voltage	Hz	Ph	Amps	Rated kW/kVA
200EOZDJ (4UA10)	120/208	60	3	694	200.0/250.0
	120/240	60	3	601	200.0/250.0
	127/220	60	3	656	200.0/250.0
	139/240	60	3	601	200.0/250.0
	277/480	60	3	301	200.0/250.0
175EFOZDJ (4UA10)	110/190	50	3	665	175.0/219.0
	110/220	50	3	574	175.0/219.0
	120/208	50	3	607	175.0/219.0
	220/380	50	3	332	175.0/219.0
	230/400	50	3	316	175.0/219.0
	240/416	50	3	304	175.0/219.0

Generator Features

- Engine is Environmental Protection Agency (EPA) Marine Tier III compliant (60 Hz model only)
- Approved for use with certified renewable Hydrotreated Vegetable Oil (HVO) / Renewable Diesel (RD) fuels compliant with EN15940 / ASTM D975.
- Superior Fast-Response® PMG excitation system
- Remote control connector
- Class H insulation
- Reconnectable voltage
- One- or three-phase reconnectable alternator
- Voltage regulation of 2%
- Frequency regulation of 0.5%

Optional Accessories

- Sound Shield
- Remote digital display
- Isolated ground system (12- or 24-volt), standard
- Circuit breakers

Optional Agency Type Approvals

- China Classification Society (CCS)
 - Lloyd's Register
 - American Bureau of Shipping (ABS)
- Agency requirements:
- Extra senders, exhaust blankets, and double wall fuel lines with leak alarm
 - 3 separate Type Approval documents for engine, alternator, and Decision-Maker® 3500 controller



RATINGS: Ratings per ISO 3046, ISO 8528-1, and Rehko ISO rating guideline 2.14. Obtain technical information bulletin (TIB-101) on ratings guidelines for complete ratings definitions. Availability is subject to change without notice. Discovery Energy, LLC reserves the right to change the design or specifications without notice and without any obligation or liability whatsoever. Contact your local authorized generator set distributor for availability. 10% overload capacity one hour in twelve hours.



200EOZDJ (60 Hz)
Marine Generator Set - 175EFOZDJ (50 Hz)
3-Phase Diesel

Application Data

Engine

Engine Specifications	60 Hz	50 Hz
Type	Inline, 4-cycle	
Number of cylinders	6	
Firing order	1-5-3-6-2-4	
Aspiration	Turbocharged and aftercooled	
Displacement, L (cu. in.)	9.0 (549)	
Bore and stroke, mm (in.)	118 x 136 (4.6 x 5.4)	
Compression ratio	16.3:1	
Combustion system	Direct injection	
Rated rpm	1800	1500
Maximum power at rated rpm, HP	298	261
Cylinder block material	Cast iron	
Cylinder head material	Cast iron	
Piston rings	2 compression/1 oil	
Crankshaft material	Forged steel	
Connecting rod material	Forged steel	
Governor type	Electronic	

Engine Electrical

Engine Electrical System	60 Hz	50 Hz
Battery, voltage	12- or 24-volt spec	
Battery, charging (12 volt)	90 amp	
Battery, charging (24 volt)	60 amp	
Battery, recommendation (minimum, 12 volt)	1100 CCA	
Battery, recommendation (minimum, 24 volt)	750 CCA	
Starter motor	Gear-reduction type	

Cooling

Cooling System	60 Hz	50 Hz
Capacity, L (U.S. qt.) (approx.)	30 (31)	
Cooling type	Heat exchanger	
Seawater pump type	John Deere gear driven	
Seawater pump suction lift, maximum, m (ft.)	3.0 (10.0)	
Heat rejected to cooling water at rated kW, wet exhaust, kW (Btu/min.)	245 (13945)	220 (12522)
Engine water pump flow, Lpm (gpm)	334 (88.2)	268 (70.8)
Seawater pump flow, Lpm (gpm)	352 (93)	299 (79)

Fuel

Fuel System	60 Hz	50 Hz
Fuel recommendation	Diesel fuel specified to EN 590 or ASTM D975	
Fuel shutoff solenoid	Electric	
Fuel injection system	High Pressure Common Rail (HPCR)	
Fuel pump priming	Manual	
Maximum recommended fuel lift, m (ft.)	3.0 (10.0)	

Lubrication

Lubricating System	60 Hz	50 Hz
Oil pan capacity with filter, L (U.S. qt.)	31.94 (33.75)	
Type	Pressure	

Operation Requirements

Air Requirements	60 Hz	50 Hz
Engine combustion air requirements, m ³ /min. (cfm)	15.7 (554)	11.6 (410)
Max. air intake restriction, kPa (in. H ₂ O)	6.25 (25)	6.25 (25)
Cooling air required for generator set at 50°C (122°F) ambient, m ³ /min. (cfm)	91.4 (3000)	76.2 (2500)
Exhaust flow, m ³ /min. (cfm)	49 (1713)	40 (1409)
Exhaust temp., °C (°F)	493 (919)	453 (847)
Max. allowed exhaust backpressure, kPa (in. H ₂ O)	7.5 (30)	7.5 (30)

Fuel Consumption

Diesel, Lph (gph) at % load	60 Hz	50 Hz
100%	59.9 (15.8)	53.1 (14.0)
75%	44.5 (11.7)	38.0 (10.0)
50%	34.8 (9.2)	25.5 (6.7)
25%	18.2 (4.8)	14.3 (3.8)

Engine Features

- One-side serviceability of fuel system, lubrication system, and air cleaner
- Low oil pressure cutout
- High water temperature cutout
- Loss of coolant cutout
- Overcrank cutout
- Belt guard
- Optional digital display
- Disposable oil filter
- Extended oil drain
- PTO options: 12- or 24-volt electric clutch

Controller Features

- A graphical display and pushbutton/rotary selector dial provide easy, local data access.
- Measurements are selectable in metric or English units.
- The controller supports Modbus[®] protocol with serial bus (RS-485) or Ethernet networks.
- Scrolling display shows critical data at a glance.
- Graphical display of power metering (kW, kVA, V, I, PF, and VAR).
- Integrated hybrid voltage regulator.
- Built-in alternator thermal overload protection.

Modbus[®] is a registered trademark of Schneider Electric.

Decision-Maker® 3500 Paralleling Controller



Provides advanced control, system monitoring, and system diagnostics for optimum performance and compatibility. The Decision-Maker® 3500 controller uses a patented hybrid voltage regulator and unique software logic to manage alternator thermal overload protection features normally requiring additional hardware. Additional features include:

- **AC Output Voltage Regulator Adjustment.** The voltage adjustment provides a maximum adjustment of $\pm 10\%$ of the system voltage.
- **Alarm Silence.** The controller can be set up to silence the alarm horn only when in the AUTO mode for NFPA-110 application or Always for user convenience.
- **Alternator Protection.** The controller provides generator set overload and short circuit protection matched to each alternator for the particular voltage/phase configuration.
- **Automatic Restart.** The controller automatic restart feature initiates the start routine and recrank after a failed start attempt.
- **Cyclic Cranking.** The controller has programmable cyclic cranking.
- **ECM Diagnostics.** The controller displays engine ECM fault code descriptions to help in engine troubleshooting.
- **Engine Start Aid.** The configurable starting aid feature provides customized control for an optional engine starting aid.
- **Event Logging.** The controller keeps a record (up to 1000 entries) for warning and shutdown faults. This fault information becomes a stored record of system events and can be reset.
- **Historical Data Logging.** Total number of successful starts of the generator is recorded and displayed.
- **Integrated Hybrid Voltage Regulator.** The voltage regulator provides $\pm 0.5\%$ no-load to full-load RMS voltage regulation with three-phase sensing.
- **Lamp Test.** Press the alarm silence/lamp test button to verify functionality of the indicator lights.
- **LCD Display.** Adjustable contrast for improving visibility.
- **Measurement Units.** The controller provides selection of English or metric displays.
- **Power Metering.** Controller graphical display provides voltage, current, power factor, kW, kVA, and kVAR.
- **Programming Access (USB).** Provides software upgrades and diagnostics with PC software tools.
- **Remote Reset.** The remote reset function supports acknowledging and resetting faults and allows restarting of the generator set without going to the master control switch off/reset position.
- **Run Time Hourmeter.** The generator set run time is displayed.
- **Time Delay Engine Cooldown (TDEC).** The TDEC provides a time delay before the generator set shuts down.
- **Time Delay Engine Start (TDES).** The TDES provides a time delay before the generator set starts.
- **Voltage Selection Menu.** This menu provides the capability to switch the generator output voltage. NOTE: Generator set output leads may require reconnection.
- **Paralleling Functions:**
 - Bus sensing
 - First on logic
 - Synchronizing
 - Communication based isochronous load sharing
 - Droop load sharing
 - External controlled load sharing via analog bias signals

Alternator Specifications

Alternator Specifications

Specifications	Alternator
Type	4-pole, rotating-field
Exciter type	Brushless, permanent-magnet, Fast-Response®
Number of leads	12, reconnectable
Voltage regulator	Solid state, volts/Hz
Insulation: NEMA MG-1.66	
Material	Class H
Temperature rise	90°C
Bearing: number, type	1, sealed
Coupling	Flexible disc
Amortisseur windings	Full
Voltage regulation, no load to full load	2%
One-step load acceptance per NFPA 110	100% of rating
Peak motor starting kVA—4UA10	785

Alternator Features

- The generator complies with NEMA, IEEE, and ANSI standards for temperature rise.
- The alternator uses a permanent-magnet, Fast-Response® excitation system.
- The alternator has a two-thirds pitch stator and skewed rotor.
- The generator has a solid-state, volts-per-hertz voltage regulator.
- The brushless, synchronous generator is broadrange and reconnectable.
- The windings are vacuum-impregnated with epoxy varnish for dependability and long life.
- Capable of sustained line-to-neutral short circuit current of up to 300% of the rated current for up to 2 seconds. Capable of sustained short circuit current of up to 300% of the rated current for up to 10 seconds for 3 phase connections. (IEC 60092-301 short-circuit performance.)

Optional Accessories

- Modular sound shield manufactured with 5052-H32 aluminum in powder-coated Matterhorn white
- Circuit breakers
- Remote digital display
- Remote monitoring, start/stop panel with wiring harness for connection to the generator controller
- Duplex fuel filter
- Siphon break
- Remote connection/extension harness
- Oil level indicator (high/low)
- Low coolant level indicator
- Isolated ground system (12- or 24-volt), standard
- Electric front clutch power takeoff (PTO) 12- or 24-volt

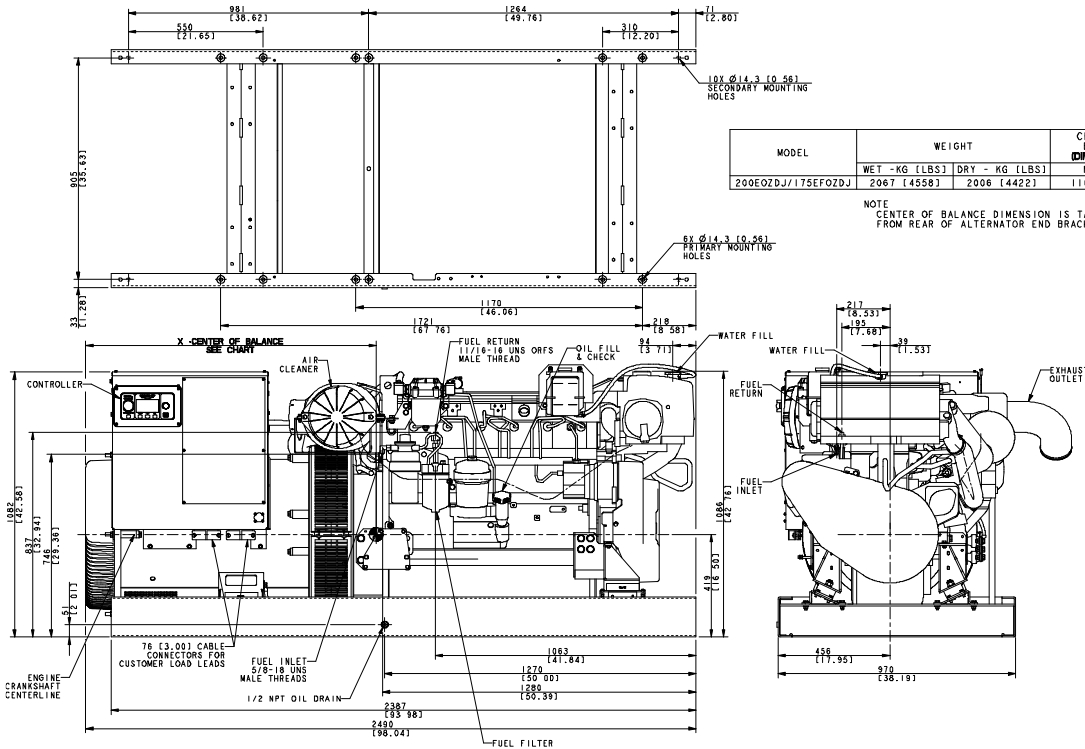

ADV-8747-A

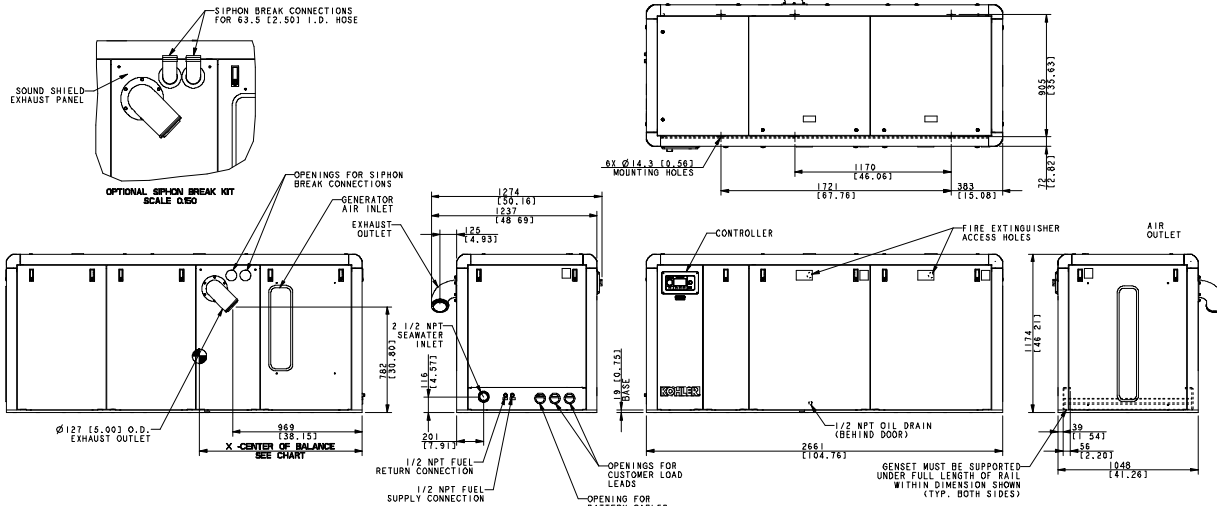

ADV-8748-A

NOTE: Dimensions are shown in mm [in.].
NOTE: This drawing is provided for reference only and is not intended for installation planning. Contact your local authorized distributor for more detailed information.