

Roots™ EasyAir* X2

Factory blower package system



Howden Roots EasyAir X2 factory blower package system includes innovative design features that reduce noise and maintenance costs while delivering reliable performance.

Basic Blower Package Description

The Roots EasyAir X2 system provides the best of performance engineering in a standard package.

It can be configured to meet unique requirements and is suitable for pressure or vacuum applications.

The Roots EasyAir X2 system is a cost-effective factory designed blower package available for your:

- Wastewater & water treatment needs
- Pneumatic conveying & bulk handling needs
- Process air needs

Package Standard Equipment

- Bi- or tri-lobe splash lubricated blower
- Drive motor is high efficiency, TEFC enclosure with 1.15 service factor
 - Or provide us with your specified motor requirements and let GE provide the solution
- Self-tensioning V-belt drive
- Inlet filter/silencer with polyester element
- Discharge silencer (non-packed; multi-chamber)
- Non-electric enclosure vent fan
- Vibration isolation pads
- Panel-mounted filter restriction gauge, system pressure/vacuum gauge, discharge temperature gauge
- Acoustic enclosure with robust painting system
- Discharge flexible connector
- Check valve
- Pressure relief valve
- Oil drain manifold with sight gauge

Package Design Features

- Easy to install, with small footprint
- Electrical access through the floor or rear panel gives you added flexibility
- Automatic belt-tensioning system is counter-balanced, optimizing the life of the V-belts
- No special jacks are required to lift the motor when replacing belts (saving time and effort)
- Side-by-side installation allows for more efficient use of your available space
- Keyed locking panels allow easy filter maintenance and safe access to equipment
- Air flow from front to rear is designed for personnel safety and equipment reliability
- Access to air filter is convenient and designed to reduce pressure losses, improving reliability and blower efficiency and protecting your investment
- Blower shaft-mounted fan provides exceptional cooling, reducing enclosure temperature dramatically and extending the life of critical components
- Gauges are provided to monitor blower health as standard equipment and positioned ergonomically for your personnel's safety
- Acoustic enclosure is designed to provide up to 22 dBA free field attenuation, helping you to meet the specified noise requirements of the jobsite
- Broad operating performance range provides you with a multitude of efficient and compact solutions so your requirements are satisfied

EasyAir X2 Package Sizes and Blower Performance Range

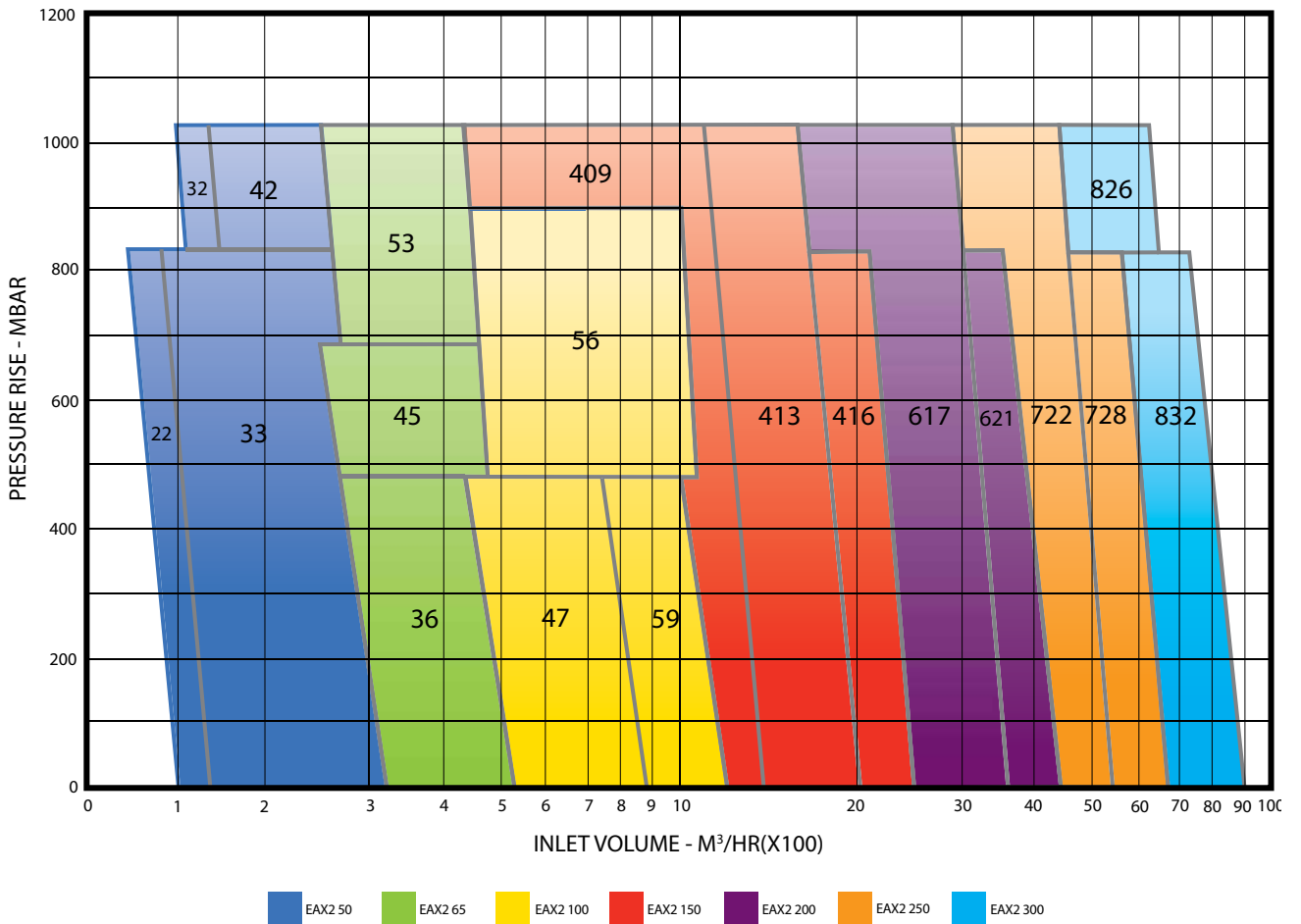
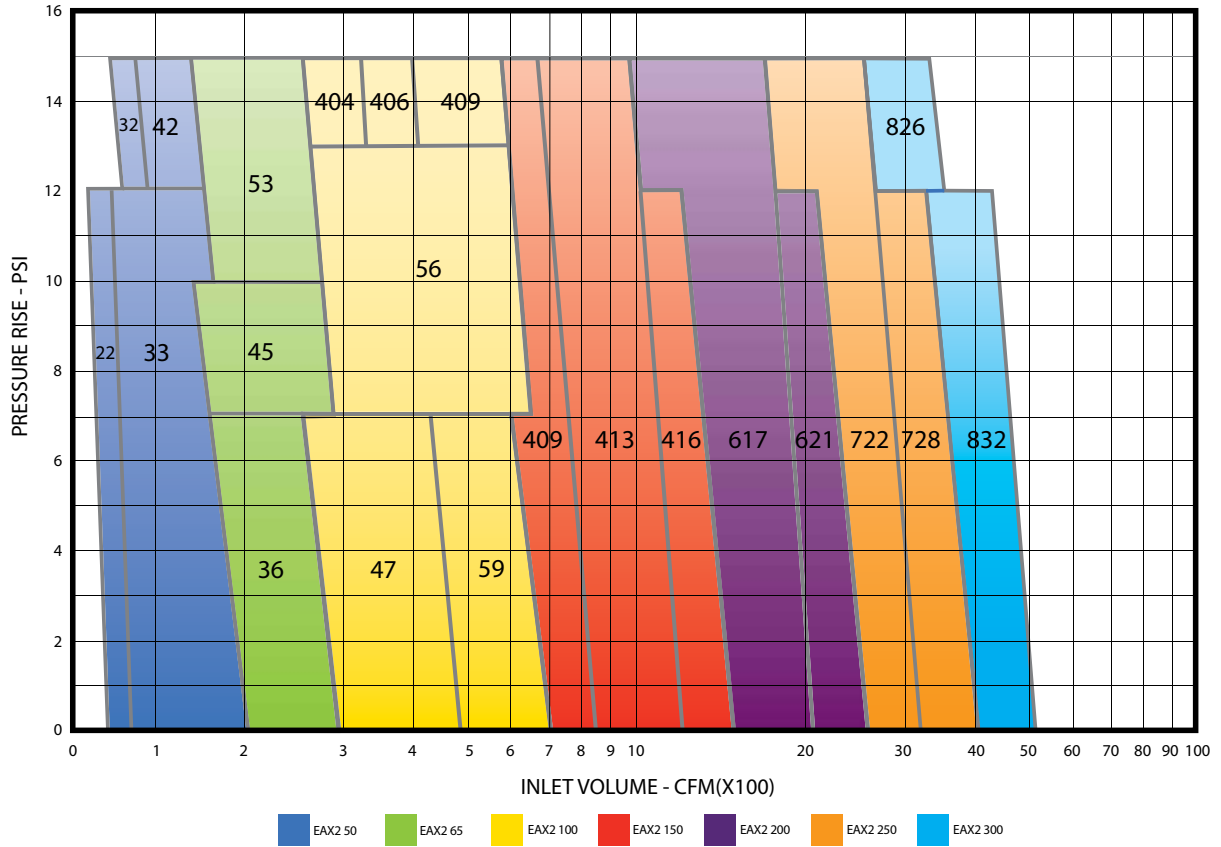

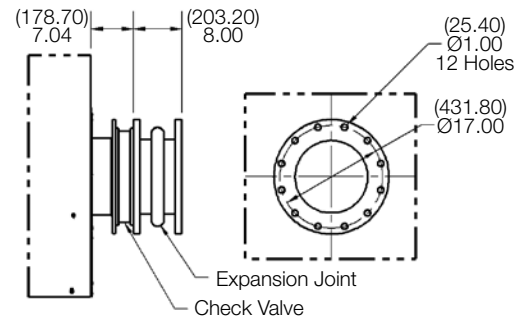
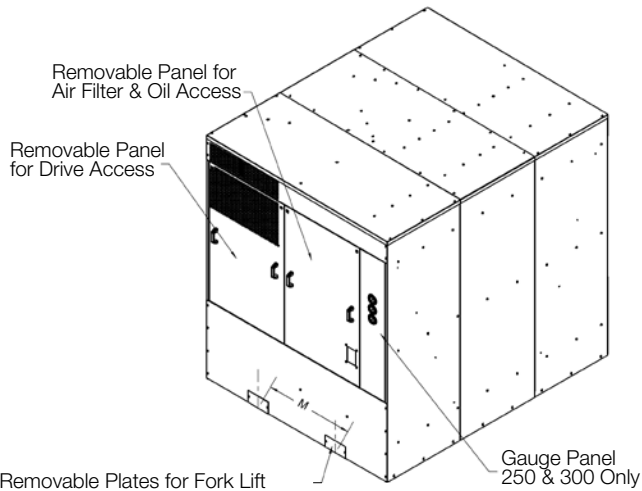

View of EasyAir X2 300 Flanged Discharge Connection

Removable Plates for Fork Lift 2.40 x 7.87 (61 x 200)

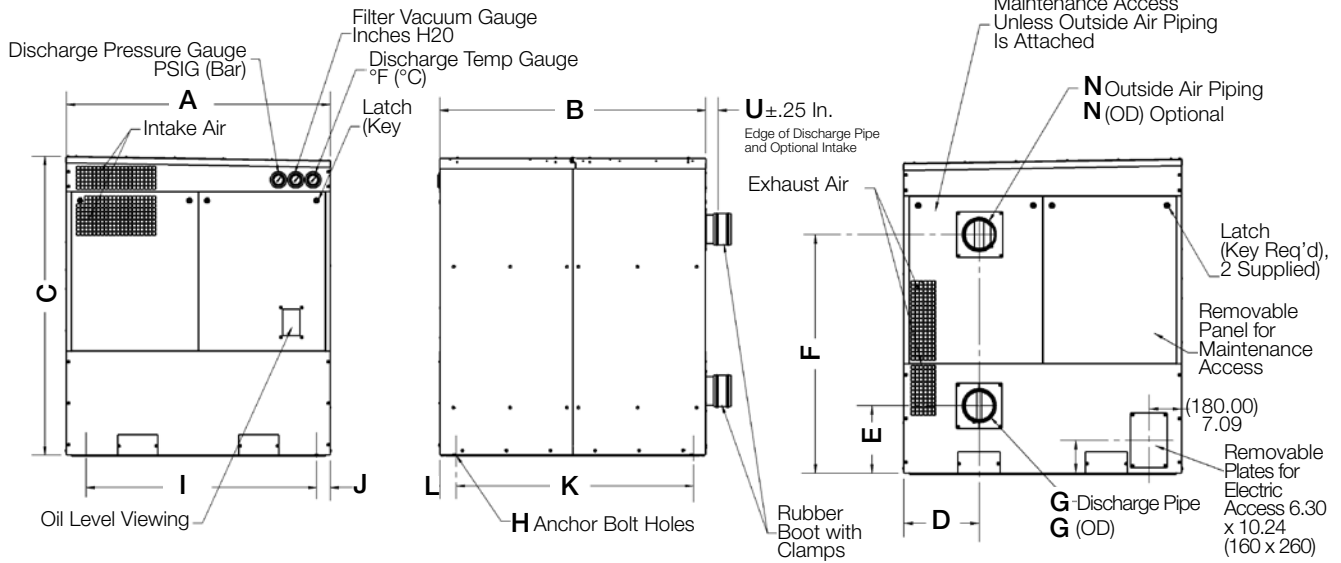

Dimension Table

Model	A	B	C	D	E	F	G	G (OD)	H	Blower Size	Approx. Weight Excluding Motor
EAX2 50	43.31 (1100)	39.36 (1000)	46.25 (1175)	10.88 (276.5)	7.66 (194.5)	33.53 (851.7)	2.00 (50)	2.38 (60.3)	0.78 (20)	URAI 22, 32, 33, 42	450-525 LBS
EAX2 65	43.31 (1100)	39.36 (1000)	46.25 (1175)	10.88 (276.5)	7.66 (194.5)	33.53 (851.7)	2.50 (65)	2.88 (73)	0.78 (20)	URAI 36, 45, 53	600-650 LBS
EAX2 100	49.21 (1250)	47.24 (1200)	59.05 (1500)	10.45 (265.5)	9.23 (234.5)	46.54 (1182)	4.00 (100)	4.50 (114)	0.78 (20)	URAI 47, 56, 59, RAM 404, 406, 409	900-1125 LBS
EAX2 150	60.03 (1250)	61.02 (1550)	67.91 (1725)	16.30 (414)	14.60 (371)	51.65 (1312)	6.00 (150)	6.60 (168)	0.78 (20)	Tri-RAM 409, 413, 416	1650-1775 LBS
EAX2 200	66.93 (1700)	70.87 (1800)	80.70 (2050)	19.72 (500.9)	17.96 (456.3)	59.80 (1519)	8.00 (200)	8.63 (219)	0.78 (20)	Tri-RAM 617, 621	2425-2550 LBS
EAX2 250	76.77 (1950)	90.55 (2300)	91.53 (2325)	24.25 (641.5)	16.98 (431.4)	69.50 (1765.2)	10.00 (250)	10.75 (273)	0.78 (20)	Tri-RAM 722, 728	3650-3900 LBS
EAX2 300	83.66 (2125)	102.36 (2600)	97.44 (2475)	27.85 (707.5)	19.93 (506.4)	77.17 (1960.1)	12.00 (300)	12" 150 #FLG	0.78 (20)	Tri-RAM 826, 832	4950-5450 LBS

Model	I	J	K	L	M	N	N (OD)	U	Blower Size	Approx. Weight Excluding Motor
EAX2 50	37.03 (940.5)	3.14 (79.95)	32.83 (834)	3.27 (83)	23.62 (600)	3.00 (76.2)	3.50 (88.9)	3.00 (75)	URAI 22, 32, 33, 42	450-525 LBS
EAX2 65	37.03 (940.5)	3.14 (79.95)	32.83 (834)	3.27 (83)	23.62 (600)	3.00 (76.2)	3.50 (88.9)	3.00 (75)	URAI 36, 45, 53	600-650 LBS
EAX2 100	42.93 (1090.5)	3.14 (79.95)	40.71 (1034)	3.27 (83)	23.62 (600)	4.00 (100)	4.50 (114)	3.00 (75)	URAI 47, 56, 59, RAM 404, 406, 409	900-1125 LBS
EAX2 150	53.76 (1365.5)	3.14 (79.95)	54.48 (1384)	3.27 (83)	27.55 (700)	6.00 (150)	6.60 (168)	3.00 (75)	Tri-RAM 409, 413, 416	1650-1775 LBS
EAX2 200	60.65 (1540.5)	3.14 (79.95)	64.33 (1634)	3.27 (83)	33.46 (850)	8.00 (200)	8.63 (219)	6.30 (160)	Tri-RAM 617, 621	2425-2550 LBS
EAX2 250	68.77 (1747)	3.99 (101.5)	84.17 (2138)	3.19 (81)	35.83 (910)	12.00 (300)	12.75 (323.9)	9.72 (247)	Tri-RAM 722, 728	3650-3900 LBS
EAX2 300	75.67 (1922)	3.99 (101.5)	95.98 (2438)	3.19 (81)	35.83 (910)	12.00 (300)	12.75 (323.9)	SEE FLG VIEW	Tri-RAM 826, 832	4950-5450 LBS

All dimensions in inches. Dimensions shown () are millimeters

View with front panels removed



View with rear panels removed



Automatic V-belt drive tensioning system



Discharge pressure, filter vacuum and discharge temperature gauges are standard



Oil fill level site glass is visible without opening panels



Discharge connection



Automatic belt tensioning system is counter-balanced to optimize V-belt life

This conduit box may be located on the left side if a NEMA motor is supplied. (IEC motor

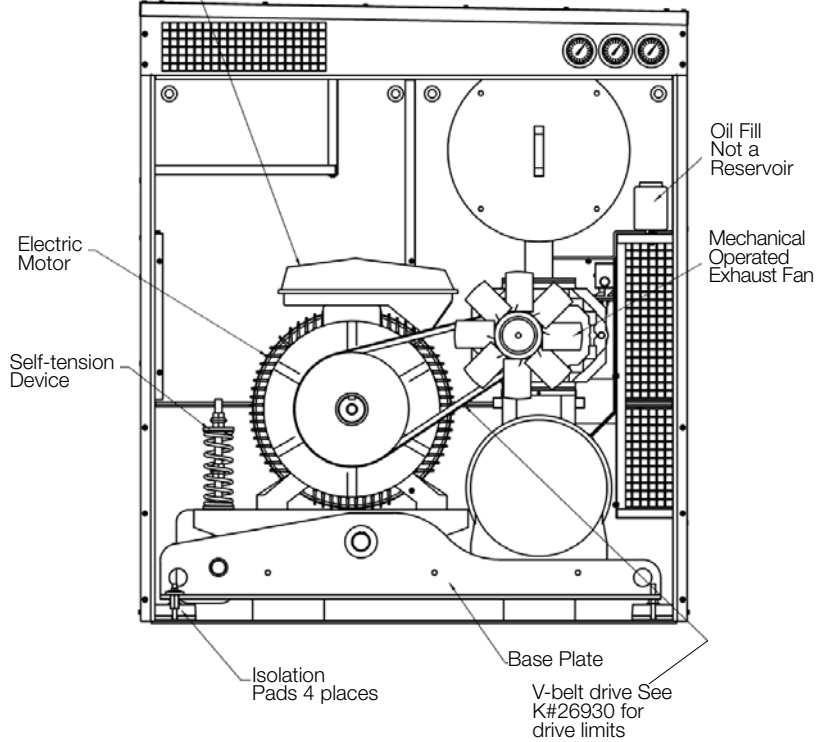

Vacuum Relief Valve Connection for Vacuum Applications. Not Available on Pressure Applications.

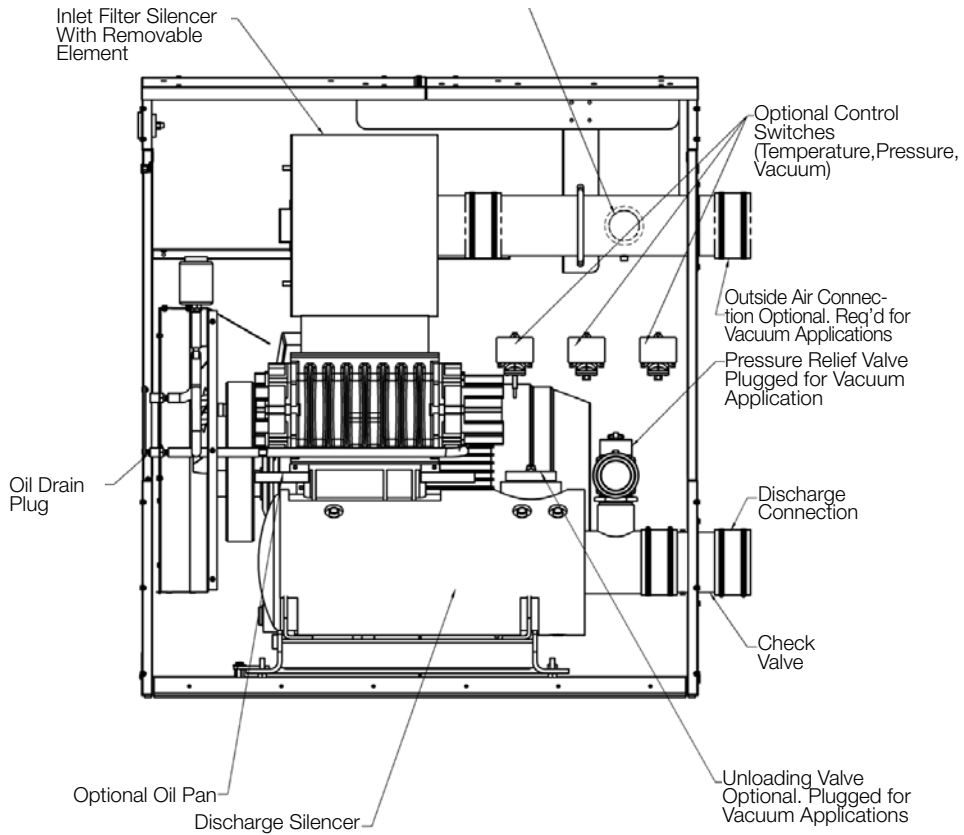

Servicing and Maintaining Your Investment

Howden owns and operates strategically located blower maintenance and repair facilities in the following areas: Connersville, Indiana, Houston, Texas, Mexico City, Mexico, Dubai, UAE, Shanghai, China.

Howden has additional authorized service capability via an extensive network of distributors and agents.

Each facility is well equipped and staffed with factory trained service personnel to meet your unique needs. These facilities regularly service competitor units and keep critical parts on hand for expedited delivery. Howden warrants all authorized maintenance and repair work with one year coverage on all parts and workmanship. Certified ISO-9001.

Warranty

Applicable Series or Model	Designation or Gear Diameter	Warranty period-months from date of original unit start-up/months from date of original shipment, whichever occurs first
Bare Shaft Unit		
URAI [®] & URAI-J [®] including DSL	2½ - 7 inch	24/30
RAM [®] & RAM-J [®]	4½ - 6 inch	24/30
Tri-RAM [®]	409, 413, 416, 617 & 621	24/30
Tri-RAM [®]	722, 728, 826 & 832	12/18
Standard Factory Package (Note that bare shaft blowers are covered separately above. Explicitly not included in standard factory package warranty are drive belts, filter elements, hoses and fittings, gauges and switches.)		
EasyAir [®] X2	50, 65, 100, 150 & 200	18/24
EasyAir [®] X2	250 & 300	12/18

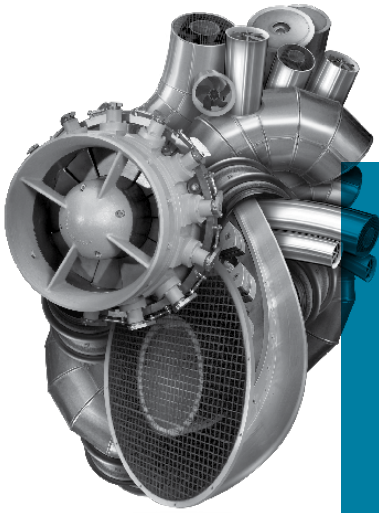

At the heart of your operations

Howden people live to improve our products and services and for over 160 years our world has revolved around our customers. This dedication means our air and gas handling equipment adds maximum value to your operations. We have innovation in our hearts and every day we focus on providing you with the best solutions for your vital operations.



Howden Roots

Howden Roots
900 W. Mount St.
Connersville
Indiana
USA
47331

Tel: +1 765 827 9200
Web: www.howden.com

Revolving Around You™